

GENADYNE

UNO Rechargeable

Single Use Negative Pressure Wound Therapy



Contents

UNO Safety Information	3
Description	3
Indications for Use	4
Contraindications	4
Warnings	5
Precautions	9
User	10
Instructions for Use	11
Symbols	23
Electromagnetic Compatibility	24
Specifications	27
Contact Information	28

UNO Safety Information

Safety Standards

This system has been designed to comply with the regulatory safety standards including UL 60601-1, CAN/CSA C22.2 No. 601.1-M90, Council Directive 93/42/EEC Class IIa.



Important: As with any prescription medical device, failure to consult a physician and carefully read and follow all therapy unit and dressing instructions and safety information prior to each use may lead to improper product performance and the potential for serious or fatal injury. Do not adjust therapy unit setting or perform therapy application without directions from/or supervision by the clinical caregiver.



WARNING: Disregarding the information on safety of this device is considered ABNORMAL USE

Description

The Genadyne UNO is a single use Negative Pressure Wound Therapy (NPWT) Unit designed for moderate to low severity wounds. The Genadyne UNO NPWT Unit has a pre-determined lifespan. The unit features an interface panel which provides alert and information signals and selectable therapy options. This unit provides negative pressure at either 80 mmHg or 125 mmHg, and offers selections of Continuous Mode at 80mmHg / 30mmHg or 125mmHg / 30mmHg in Variable Mode. The Genadyne UNO Therapy Kits include a therapy unit, 70 cc canisters, USB charger, USB cable and sterile dressing kits. Dressing kits and canisters for the Genadyne UNO could be provided separately. Dressing should be changed in line with standard wound dressing guidelines, typically every 3 to 4 days. More frequent changes may be required depending on level of exudate, condition of dressing, wound type/sizes, orientation of the dressing, environmental considerations or other patient considerations; e.g. when UNO is used on infected wounds. At the healthcare professional's discretion an UNO dressing may be left in place for up to 7 days.

Disposable components of the Genadyne UNO, including the foam dressing and drape, are packaged sterile. All disposable components of the Genadyne UNO are for single use only. To help ensure safe and effective use, the Genadyne UNO dressings are to be used only with the UNO Negative Pressure Therapy Unit.

The decision to use clean versus sterile/aseptic technique is dependent upon wound pathophysiology, physician/clinician preference and institutional protocol.

Indications for Use

Genadyne UNO is indicated for use in patients who would benefit from negative pressure wound therapy particularly as the device may promote wound healing by the removal of low to moderate exudates and infectious material.

Appropriate wound types include:

- Chronic
- Acute
- Traumatic
- Subacute and dehisced wounds
- Partial-thickness burns
- Ulcers (such as diabetic or pressure)
- Flaps and grafts
- Closed surgical incision

It is a single patient use device.

Contraindications

- Do not place foam dressings of the Genadyne UNO NPWT system directly in contact with exposed blood vessels, anastomotic sites, organs, or nerves.

NOTE: Refer to Warnings section for additional information concerning bleeding.

- The Genadyne UNO NPWT is contraindicated for patients with:
 - Malignancy in the wound bed or margins of the wound except palliative care to enhance quality of life
 - Previously confirmed or untreated osteomyelitis

NOTE: Refer to Warnings section for osteomyelitis information.

- Non-enteric and unexplored fistulas
- Necrotic tissue with eschar present

NOTE: After debridement of necrotic tissue and complete removal of eschar, Genadyne UNO NPWT may be used.

- Exposed arteries, veins, nerves or organs
- Exposed anastomotic sites
- Emergency airway aspiration
- Pleural, mediastinal or chest tube drainage
- Surgical suction

Warnings

Bleeding: With or without using the Genadyne UNO NPWT, certain patients are at high risk of bleeding complications. The following types of patients are at increased risk of bleeding which, if uncontrolled, could be potentially fatal.

- Patients who have weakened or friable blood vessels or organs in or around the wound as a result of, but not limited to:
 - Suturing of the blood vessel (native anastomoses or grafts)/organ
 - Infection
 - Trauma
 - Radiation
- Patients without adequate wound hemostasis.
- Patients who have been administered anticoagulants or platelet aggregation inhibitors.
- Patients who do not have adequate tissue coverage over vascular structures.

If the Genadyne UNO NPWT is prescribed for patients who have an increased risk of bleeding complications, they should be treated and monitored in a care setting deemed appropriate by the treating physician.

If active bleeding develops suddenly or in large amounts during wound therapy, or if frank (bright red) blood is seen in the tubing or in the canister, immediately stop the Genadyne UNO NPWT, leave dressing in place, take measures to stop the bleeding and seek immediate medical assistance. The Genadyne UNO NPWT Unit and dressings should not be used to prevent, minimize or stop vascular bleeding.

Protect Vessels and Organs: All exposed or superficial vessels and organs in or around the wound must be completely covered and protected prior to the administration of Genadyne UNO NPWT.

Always ensure that the dressing does not come in direct contact with vessels or organs. Use of a thick layer of natural tissue should provide the most effective protection. If a thick layer of natural tissue is not available or is not surgically possible, multiple layers of fine-meshed, non-adherent materials or bio-engineered tissue may be considered as an alternative, if deemed necessary by the treating physician, to provide a complete protective barrier. If using non-adherent materials, ensure that they are secured in a manner as to maintain their protective position throughout therapy.

Consideration should also be given to the negative pressure setting and therapy mode used when initiating therapy.

Caution should be taken when treating large wounds that may contain hidden vessels, which may not be readily apparent. The patient should be closely monitored for bleeding in a care setting deemed appropriate by the treating physician.

Infected Blood Vessels: Infection may erode blood vessels and weaken the vascular wall which may increase susceptibility to vessel damage through abrasion or manipulation. Infected blood vessels are at risk of complications, including bleeding which, if uncontrolled, could be potentially fatal. Extreme caution should be used when Genadyne UNO NPWT is applied in close proximity to infected or potentially infected blood vessels. (*Refer to **Protect Vessels and Organs** section above*)

Hemostasis, Anticoagulants and Platelet Aggregation Inhibitors: Patients without adequate wound hemostasis have an increased risk of bleeding which, if uncontrolled, could be potentially fatal. These patients should be treated and monitored in a care setting deemed appropriate by the treating physician.

Caution should be used in treating patients on doses of anticoagulants or platelet aggregation inhibitors thought to increase their risk for bleeding (relative to the type and complexity of the wound). Consideration should be given to the negative pressure setting and therapy mode used when initiating therapy.

Hemostatic Agents Applied at the Wound Site: Non-sutured hemostatic agents (for example, bone wax, absorbable gelatin sponge or spray wound sealant) may, if disrupted, increase the risk of bleeding which, if uncontrolled, could be potentially fatal. Protect against dislodging such agents.

Sharp Edges: Bone fragment or sharp edges could puncture protective barriers, vessels or organs causing injury. Any injury could cause bleeding which, if uncontrolled, could be potentially fatal. Beware of possible shifting in the relative position of tissues, vessels, or organs within the wound that might increase the possibility of contact with sharp edges. Sharp edges or bone fragments must be eliminated from the wound area or covered to prevent them from puncturing blood vessels or organs before the application of Genadyne UNO NPWT. Where possible, completely smooth and cover any residual edges to decrease the risk of serious or fatal injury should shifting of structures occur. Use caution when removing dressing components from the wound so that wound tissue is not damaged by unprotected sharp edges.

Infected Wounds: Infected wounds should be monitored closely and may require more frequent dressing changes than non-infected wounds, dependent upon factors such as wound conditions and treatment goals. Refer to dressing application instructions for details regarding dressing change frequency. As with any wound treatment, clinicians and patients/caregivers should frequently monitor the patient's wound, periwound tissue and exudate for signs of infection, worsening infection, or other complications. Some signs of infection are fever, tenderness, redness, swelling, itching, rash, increased warmth in the wound or periwound area, purulent discharge, or strong odor. Infection can be serious and can lead to complications such as pain, discomfort, fever, gangrene, toxic shock, septic shock and/or fatal injury. Some signs or complications of systemic infection are nausea, vomiting, diarrhea, headache, dizziness, fainting, sore throat with swelling of the mucus membranes, disorientation, high fever, refractory and/or orthostatic hypotension, or erythroderma (a sunburn-like rash). If there are any signs of the onset of systemic infection or advancing infection at the wound site, contact a physician immediately to determine if Genadyne UNO NPWT should be discontinued. For wound infections relating to blood vessels, please also refer to the section titled Infected Blood Vessels.

Osteomyelitis: The Genadyne UNO NPWT system should NOT be initiated on a wound with untreated osteomyelitis. Consideration should be given to thorough debridement of all necrotic, non-viable tissue, including infected bone (if necessary), and appropriate antibiotic therapy.

Protect Tendons, Ligaments and Nerves: Tendons, ligaments and nerves should be protected to avoid direct contact with UNO dressings. These structures may be covered with natural tissue, meshed non-adherent material, or bio-engineered tissue to help minimize risk of desiccation or injury.

Dressing Removal: UNO dressings are not bio-absorbable. Always count the total number dressings used to ensure the same number dressings are removed. Dressings retained in the wound for greater than the recommended time period may foster ingrowth of tissue into the wound, create difficulty in removing foam from the wound, or lead to infection or other adverse events. If dressing adheres to the wound, consider introducing sterile water or normal saline into the dressing, waiting 15-30 minutes, then gently removing the dressing from the wound. Regardless of treatment modality, disruption of the new granulation tissue during any dressing change may result in bleeding at the wound site. Minor bleeding may be observed and considered expected. However, patients with increased risk of bleeding, as described in the Bleeding section, have a potential for more serious bleeding from the wound site. If significant bleeding develops, immediately discontinue the use of the UNO Therapy System, take measures to stop the bleeding, and do not remove the foam dressing until the treating physician or surgeon is consulted. Do not resume the use of the UNO Therapy System until adequate hemostasis has been achieved and the patient is not at risk for continued bleeding.

Acrylic Adhesive: The Genadyne UNO strip has an acrylic adhesive coating, which may present a risk of an adverse reaction in patients who are allergic or hypersensitive to acrylic adhesives. If a patient has a known allergy or hypersensitivity to such adhesives, do not use the Genadyne UNO NPWT system. If any signs of allergic reaction or hypersensitivity develop, such as redness, swelling, rash, urticarial, or significant pruritus, discontinue use and consult a physician immediately. If bronchospasm or more serious signs of allergic reaction appear, seek immediate medical assistance.

Defibrillation: Remove the UNO dressing if defibrillation is required in the area of dressing placement. Failure to remove the dressing may inhibit transmission of electrical energy and/or patient resuscitation.

Magnetic Resonance Imaging (MRI) – Therapy Unit: The Genadyne UNO NPWT Device is MR unsafe. Do not take the Genadyne UNO NPWT Device into the MR environment.

Magnetic Resonance Imaging (MRI) UNO Dressing: UNO dressing can typically remain on the patient with minimal risk in an MR environment.

Hyperbaric Oxygen Therapy (HBO): Do not take the Genadyne UNO NPWT Device into a hyperbaric oxygen hazard. After disconnecting the Genadyne UNO NPWT Device, either (i) replace the UNO dressing with another HBO compatible material during the hyperbaric treatment, or (ii) cover the tubing of the UNO dressing with moist cotton gauze. For HBO therapy, the tubing must not be clamped.

Precautions

Standard Precautions: To reduce the risk of transmission of bloodborne pathogens, apply standard precautions for infection control with all patients, per institutional protocol, regardless of their diagnosis or presumed infection status. In addition to gloves, use gown and goggles if exposure to body fluids is likely.

Continuous Mode versus Variable Mode: Continuous, rather than Variable Mode, is recommended over unstable structures, such as an unstable chest wall or non-intact fascia, in order to help minimize movement and stabilize the wound bed. Continuous therapy is also generally recommended for patients at increased risk of bleeding, highly exuding wounds, fresh flaps and grafts and wounds with acute enteric fistulae.

Patient Size and Weight: The UNO NPWT has not been studied on pediatric patients. Patient size and weight should be considered when prescribing this therapy. Also, patients with highly exuding wounds or large wounds in relation to the patient size and weight should be closely monitored, as they have a risk of excessive fluid loss and dehydration. When monitoring fluid output, consider the volume of fluid in both the tubing and canister.

Spinal Cord Injury: In the event a patient experiences autonomic dysreflexia (sudden changes in blood pressure or heart rate in response to stimulation of the sympathetic nervous system), discontinue Genadyne UNO NPWT to help minimize sensory stimulation and seek immediate medical assistance.

Bradycardia: To minimize the risk of bradycardia, Genadyne UNO NPWT must not be placed in proximity to the vagus nerve.

Protect Periwound Skin: Consider use of barrier skin protector to protect periwound skin. Protect fragile/friable periwound skin with additional UNO strip, hydrocolloid, or other transparent film.

- Multiple layers of the UNO strip may decrease the moisture vapor transmission rate, which may increase the risk of maceration.
- If any signs of irritation or sensitivity to the strip, dressing, or tubing assembly appear, discontinue use and consult a physician.
- To avoid trauma to the periwound skin, do not pull or stretch the strip over the dressing during strip application.
- Extra caution should be used for patients with neuropathic etiologies or circulatory compromise.

Circumferential Dressing Application: Avoid use of circumferential dressings, except in the presence of anasarca or excessively weeping extremities, where a circumferential strip technique may be necessary to establish and maintain a seal. Consider using multiple small pieces of strips rather than one piece to minimize the risk of decreased distal circulation. Extreme care should be taken not to stretch or pull the strip when securing it, but let it attach loosely and stabilize the edges with an elastic wrap, if necessary. When using circumferential strip applications, it is crucial to systematically and recurrently palpate distal pulses and assess distal circulatory status. If circulatory compromise is suspected, discontinue therapy, remove dressing and contact a physician.

User

The Genadyne UNO is intended to be operated by qualified clinical caregivers in acute or extended settings. In-service and training programs for use of the Genadyne UNO are available. Patients are not expected to apply or change the Genadyne UNO dressings or adjust therapy unit settings.

Instructions for Use

a. Genadyne UNO NPWT

The Genadyne UNO NPWT Device is a single use NPWT device designed for moderate to low severity wounds. The Genadyne UNO has a pre-determined lifespan. The therapy unit features an interface panel which provides alerts and information signals and selectable therapy options. This unit provides negative pressure at either 80 mmHg or 125 mmHg in Continuous Mode and 80mmHg / 30mmHg or 125mmHg / 30mmHg in Variable Mode. The Genadyne UNO Therapy Kits includes a therapy unit, 70 ml canisters, USB charger, USB cable and dressing kits.

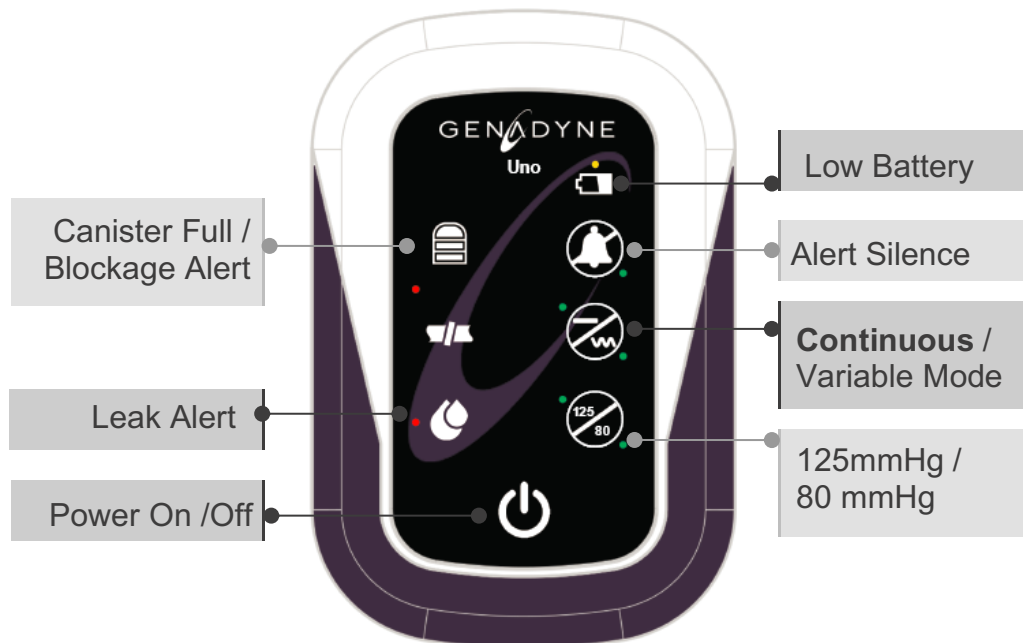

CAUTION: Once therapy is on for 30 minutes continuously, the lifespan counter begins and continues even if unit is turned off.

WARNING: The Genadyne UNO NPWT Device has no serviceable parts and should not be opened, disassembled, or otherwise modified by the user and should be replaced as a device. All assembly, operations, adjustments, modifications, maintenance and repairs must be carried out by qualified personnel authorized by Genadyne.

Electric Shock Hazard: Do not take the therapy device apart.

b. Duration of Therapy

When the therapy begins, all LEDs will flash to indicate that the unit has been turned on. After which, the subsequent LED actions before the unit turns on will indicate the remaining life time of the device. Each static LED refers to 7 day period and each LED flash refers to a 1 day period. The addition of each static and flashing LEDs equals the remaining life time of the device. Examples are below:

Static LED	Flashing LED	Remaining Life Time
4	2	30 Days remaining
3	7	28 Days remaining
3	4	25 Days remaining
2	5	19 Days remaining
2	1	15 Days remaining
1	7	14 Days remaining
1	2	09 Days remaining
0	7	07 Days remaining
0	1	01 Days remaining

At the end of therapy, the therapy device must be replaced with a new therapy unit or alternative therapy must be used. Patients should be instructed to contact the treating physician or caregiver if therapy device turns off and cannot be restarted before therapy is scheduled to end.

NOTE: Once therapy is on for 30 minutes continuously, the device's lifespan counter begins and continues even if unit is turned off.

c. Dressing Application

1. If necessary, irrigate the wound with sterile saline and pat the wound dry.

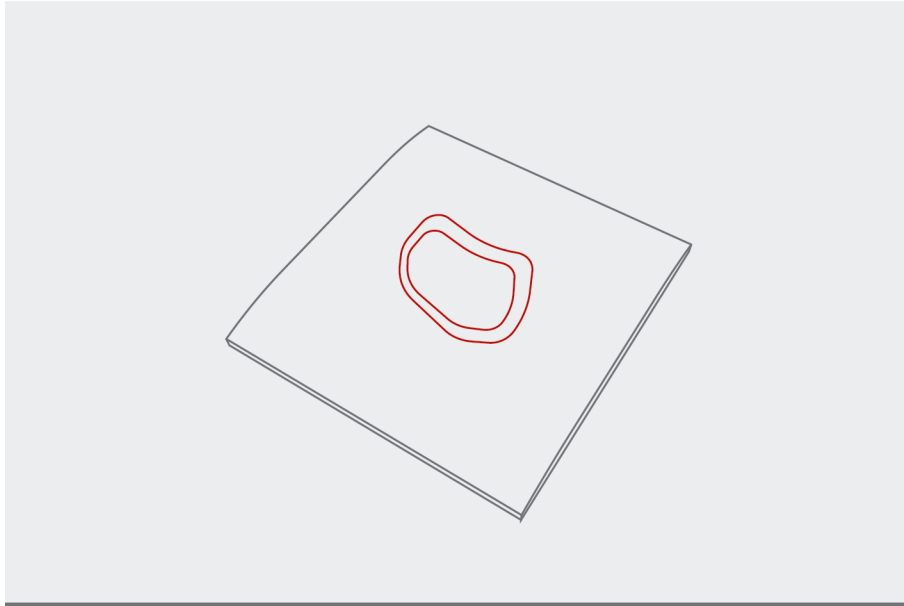

2. Using a clean technique, peel off the release liner and place the dressing centrally over the wound to reduce the chance of wound fluid coming into contact with the port. The port should be uppermost from the wound (depending on the patient's primary position), placed on intact skin and not extending over the wound to prevent fluid pooling around the port and blocking the negative pressure. Remove the other liner and flatten the dressing around the wound to prevent creasing. Reposition if required to ensure border is not creased.

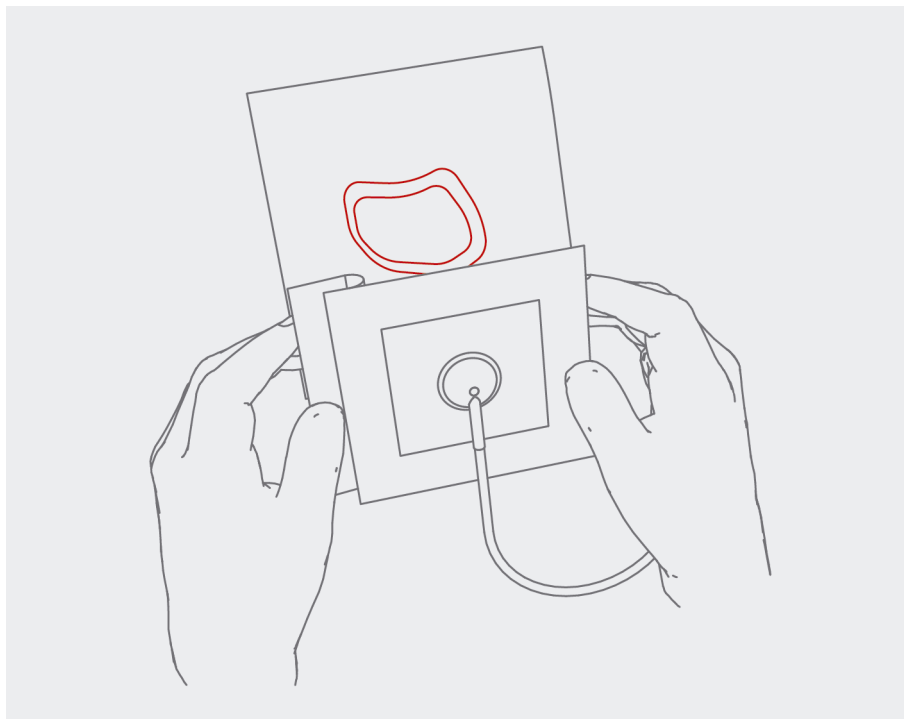
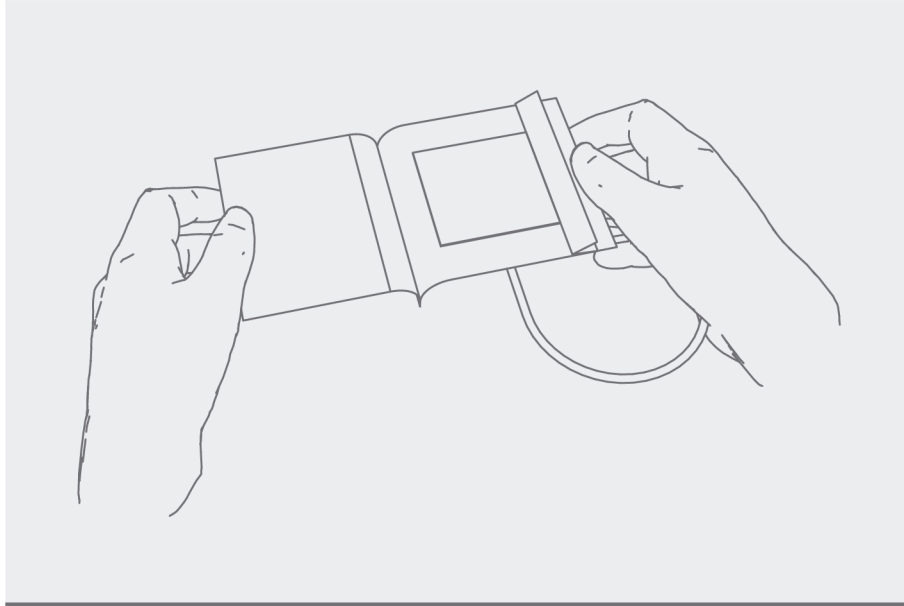

3. If using skin prep prior to application of the fixation strips, wipe the area surrounding the dressing and allow skin to dry.
4. Apply the fixation strips to each of the four sides of the dressing if the clinician feels it is necessary. Remove top carrier on the strip after each one has been applied. These strips maintain the seal over the wear time of the dressing. In awkward areas, it may be useful to apply the strips to help achieve a seal prior to switching

on the pump. Place each strip so that it overlaps the dressing border by approximately 1cm (2/5 inch). Ensure tubing is not twisted or trapped between clothing. Please note that if at any time the fixation strips are removed, the dressing should also be replaced.

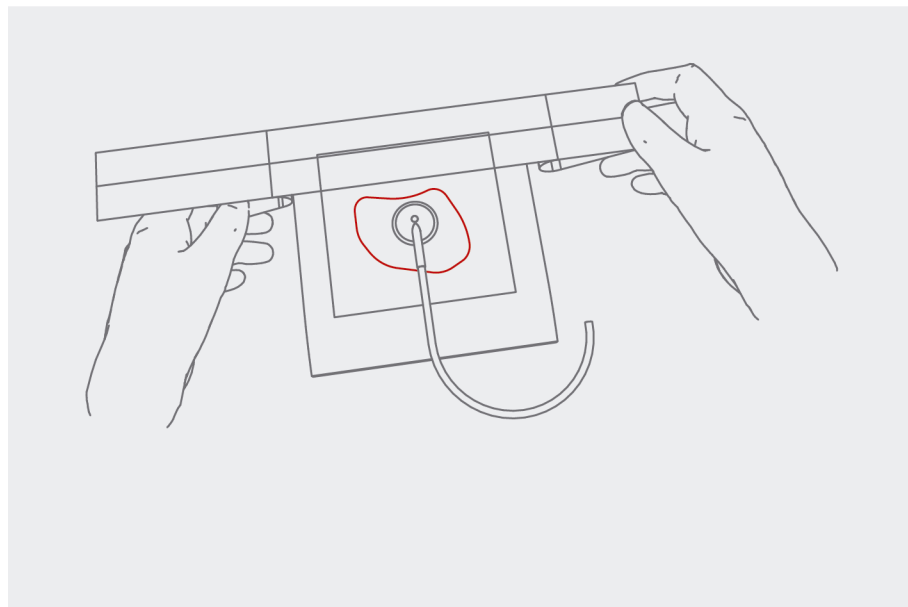
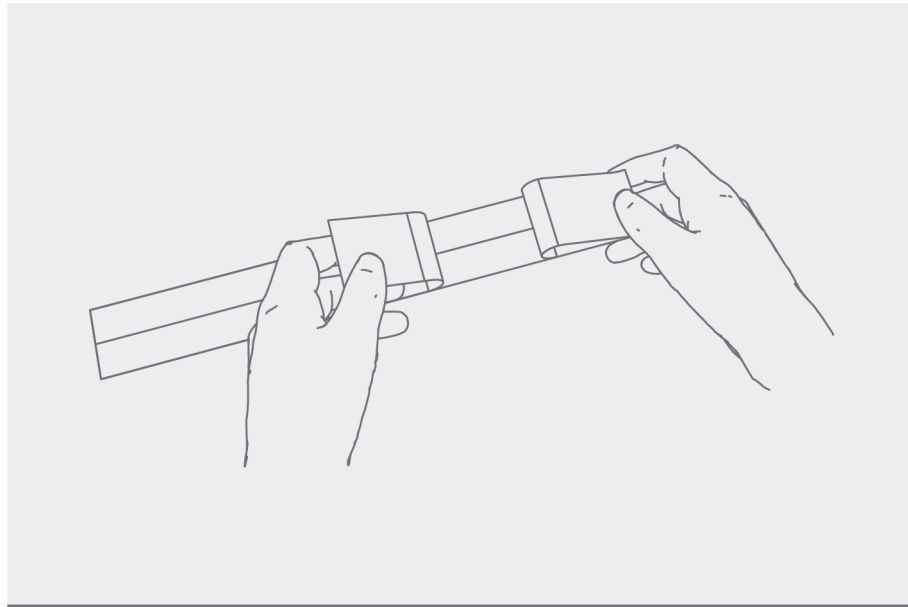

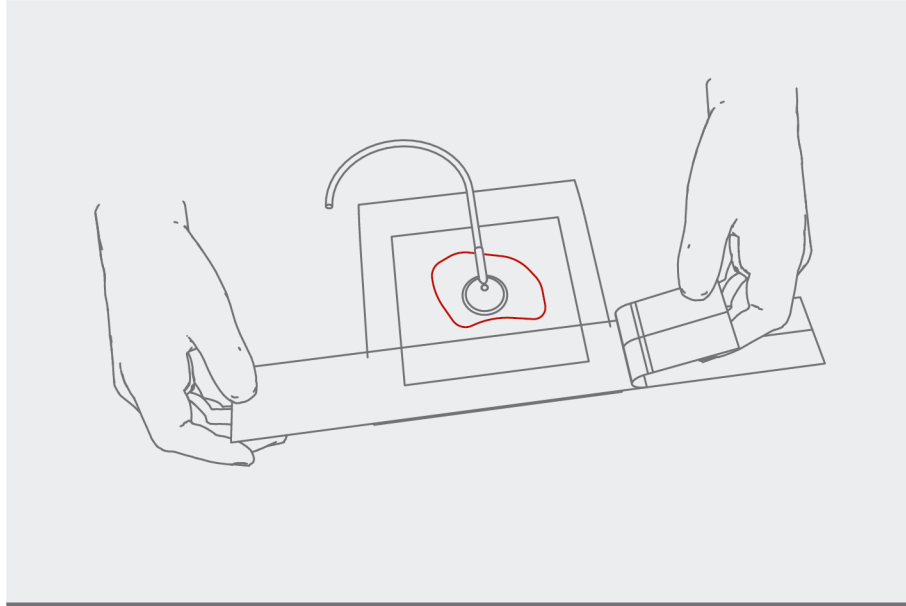

5. Once the dressing is in place, take the device out of the box.
6. Take one of the canisters from the box and clip the canister onto the back of the device. Make sure both side clips are locked and secured with the device.
7. Attach the canister's luer connector to the dressing's luer connector by twisting it until it is secured.

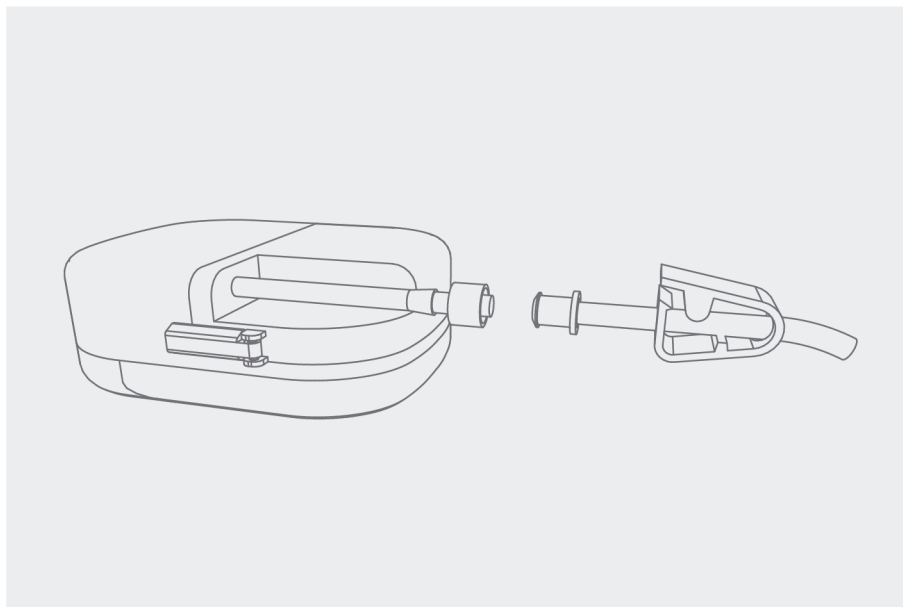

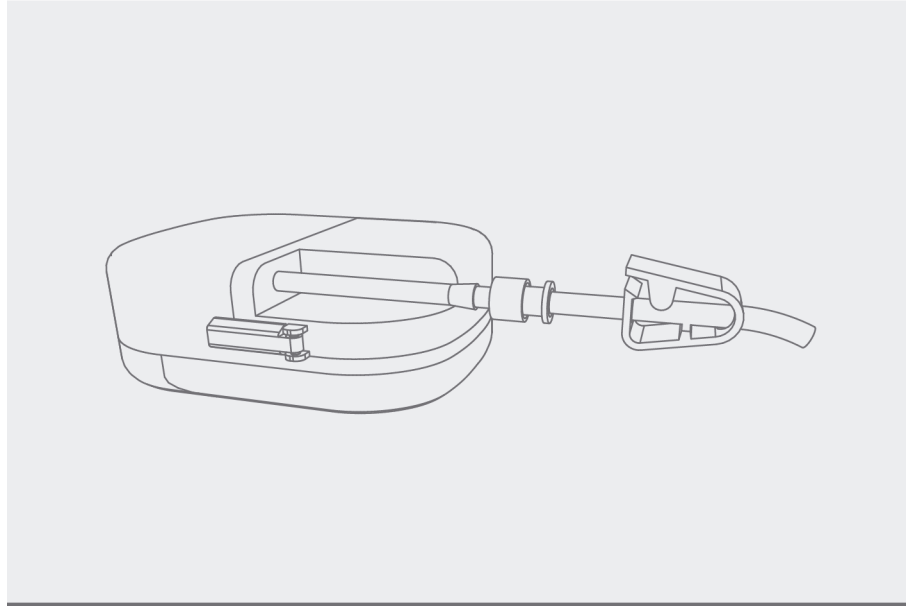



8. Press and hold the power  button for 3 seconds to start the therapy.

9. LED on the front panel indicates what pressure/mode is currently selected. If the LED on the left side is on, the device is on Continuous Mode. If the LED on the right side is on, the device is on Variable Mode:

 Device is on Continuous Mode

 Device is on Variable Mode

10. Select therapy pressure of 80 mmHg or 125 mmHg by pressing 125/80 button. The green LED next to the button will indicate the selected pressure:

 Device is on 125mmHg

 Device is on 80mmHg

11. Select Continuous or Variable Mode by pressing and holding the “-/~” button for 2 seconds. *NOTE: Continuous Mode maintains the selected therapy at a constant pressure and Variable Mode cycles the selected therapy as follows:*



- Variable 80 mmHg – Pressure will cycle between 30 mmHg and 80 mmHg every 3 minutes.



- Variable 125 mmHg – Pressure will cycle between 30 mmHg and 125 mmHg every 3 minutes.
- *NOTE: To prevent accidental change of settings, each button press will have to be held down for 2 seconds in order for the settings to be changed.*
- *NOTE: Press silence for 5 seconds to lock or unlock the keypad.*

12. Check dressing to ensure seal integrity. The dressing should be collapsed and should have a wrinkled appearance. There should be no hissing sounds.

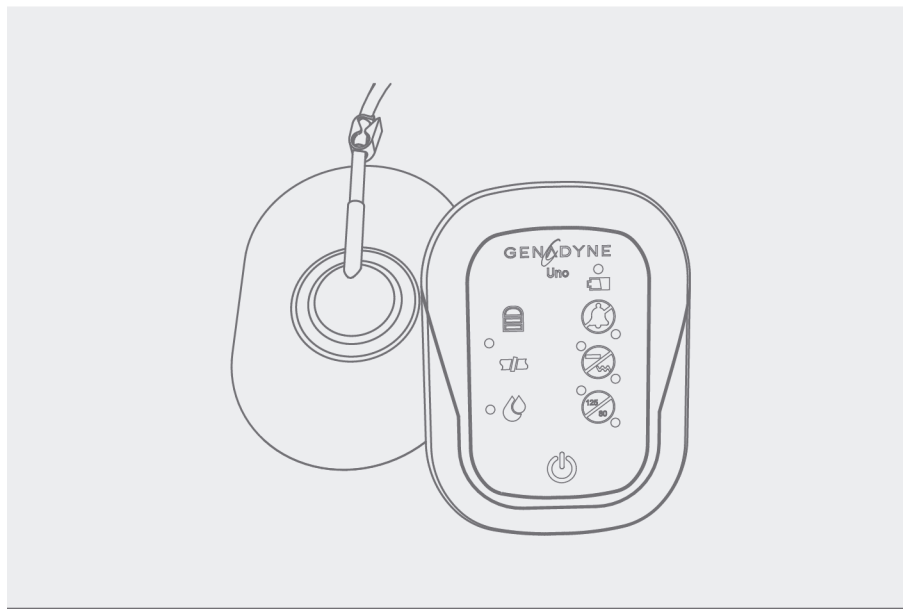

13. If there is any evidence of non-integrity, check the dressing seals, tubing connection, canister connection and ensure clamp is open.

14. If there is any evidence of a leak, refer to the **Correcting a Leak Condition** section in this manual.
15. Secure excess tubing to prevent interference with patient mobility.
16. Place the therapy device into the carrying case. Ensure display is visible through the opening in the carrying case.
17. The carrying case comes with both an adjustable strap and belt clip for carrying. The belt clip and additional clips on each side and at the bottom of the carrying case provide a place where excess tubing may be wrapped and stored to help prevent/minimize tripping.

CAUTION: Do not wear strap around neck.

d. Dressing Removal

NOTE: *If dressing is lifted to observe wound, do not re-adhere the same dressing. A new dressing must be applied.*

1. Turn therapy unit off by pressing the power button.
2. Gently stretch the strips horizontally to release the adhesive from the skin.
3. Do not peel vertically. Gently remove the drape from the wound.
4. Clean any residual adhesive with alcohol swab.

NOTE: *The dressing should be disposed as clinical waste according to institution and local environmental regulations. Additionally, if the dressing's packaging is damaged or open, do not use it. Instead dispose it according to institution and local environmental regulations and use a new dressing.*

If a new dressing is to be applied:

1. Ensure that area is clean, using an alcohol swab or antiseptic wipe.
2. Allow skin to dry completely before applying.
3. Follow **Dressing Application** instruction in this manual.

e. Canister Removal and Replacement

1. Turn therapy off.
2. Slide the canister tubing clamp close to the luer connectors and clamp it.

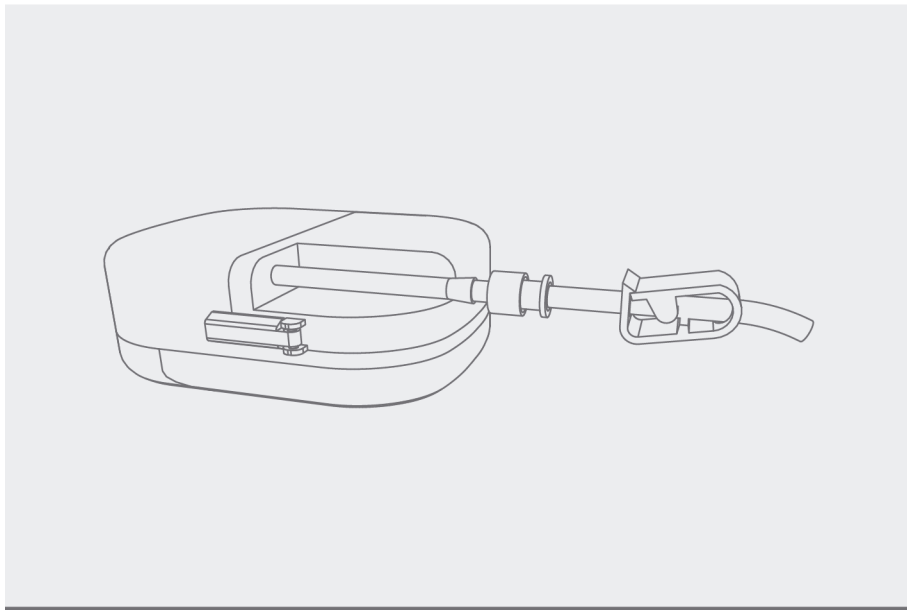
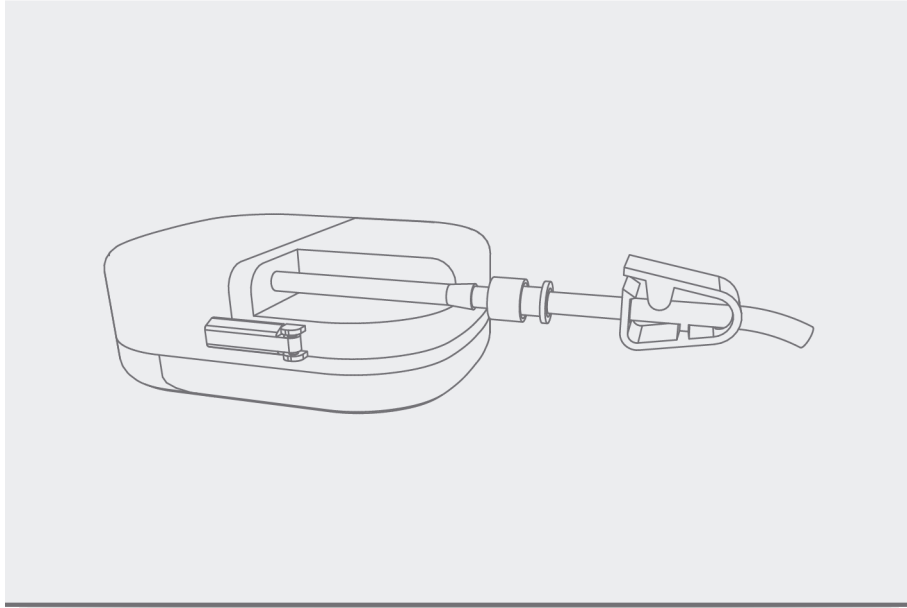

3. Disconnect the dressing from canister by untwisting the luer connectors

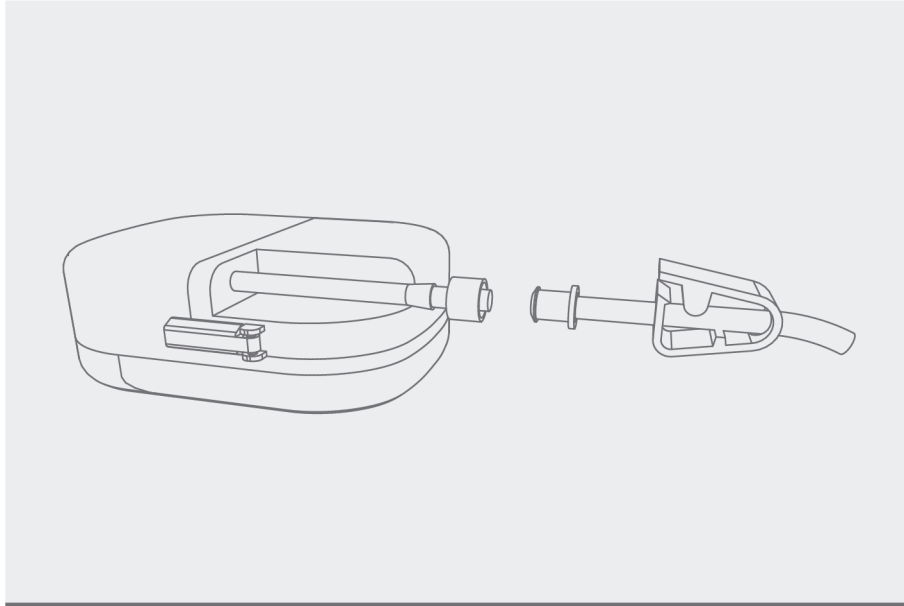

4. Remove therapy unit from carrying case
5. Unclip the two side clips of the canister to detach from UNO NPWT.
6. Install new canister.
7. Insert UNO back to carrying case
8. Reattach dressing tubing to canister tubing port.
9. Release tubing clamp.
10. Turn on the UNO.

NOTE: Dispose of used canister and dressings, according to institution and local environmental regulations.

f. Alerts

Canister Full / Blockage

When there is an obstruction of air flow, a visual and audible alert will activate:



Ensure that tubing and dressing are installed completely and without any kinks to avoid leaks or blockages in the vacuum circuit.

If the canister is found to be full, please change to a new canister.

Blockage / Kink in the tubing

Periodically, it is advisable to check the dressing integrity on the wound. If you see that the wound is puffed up but the UNO is not alerting a leak, please check if there is a kink in the tubing, or a clamp that has not been unclamped. Also, check if there is any blockage along the tubing of the dressing and the canister.

Leak

When the UNO detects a significant leak, a visual and audible alert will activate:



Correcting a Leak Condition:

1. Slowly run hand and fingers around edge of dressing pressing down firmly to ensure good contact between adhesive and skin to verify a good seal. If a leak source is identified, patch with additional strip to ensure seal integrity.
2. Ensure canister is securely locked onto the therapy unit. When canister is installed, a distinct click will be heard indicating it has been properly installed. Canister should be flush with the therapy unit with no space between the two components.
3. Check dressing tubing connector at canister.
4. When leak condition has been corrected, audible alerts will stop and visual alert will turn off.

NOTE: Upon correcting a leak condition, a small delay will occur before the therapy unit senses the correction and silences the alert.

Low Battery Level Alert

When the battery level is low (approximately 2 hours of therapy remain), a flashing orange LED on the battery level icon will turn on with audible alert sound.

When the batteries are fully charged, it is expected to last for up to 19 hours of running time per charge with good dressing integrity¹

Please connect the unit to the charger provided .

¹ Usage is based on dressing integrity. If the dressing or film is not applied properly, then the pump will require more cycles to provide the wound with required pressure. This will shorten the pump life. If the dressing has a leakage free application, then the pump will last longer.



Therapy Ended

If the device has completed its lifespan and has timed out, when an attempt is made to turn on the device, all LEDs will flash once and the device will sound an audible alert once and then shut off.

The therapy unit should be removed by your doctor.

Audible Alerts: All audible alerts will beep and repeat until the issue is fixed.

Alerts Silence Button: Press the Alert Silence button during an alert condition to silence the audible alert. The alert will reoccur every 2 minutes.

Device Disposal

At the end of therapy, follow local institutional protocols for infection control and waste disposal procedures for dressings and canisters. Local protocols for the disposal of the Genadyne UNO NPWT device should be based on the applicable federal, state and/or local government environmental regulations for recycling electronic devices.

g. Recharging Battery

1. The USB charger and USB cable shown below are provided in the UNO Therapy kit.

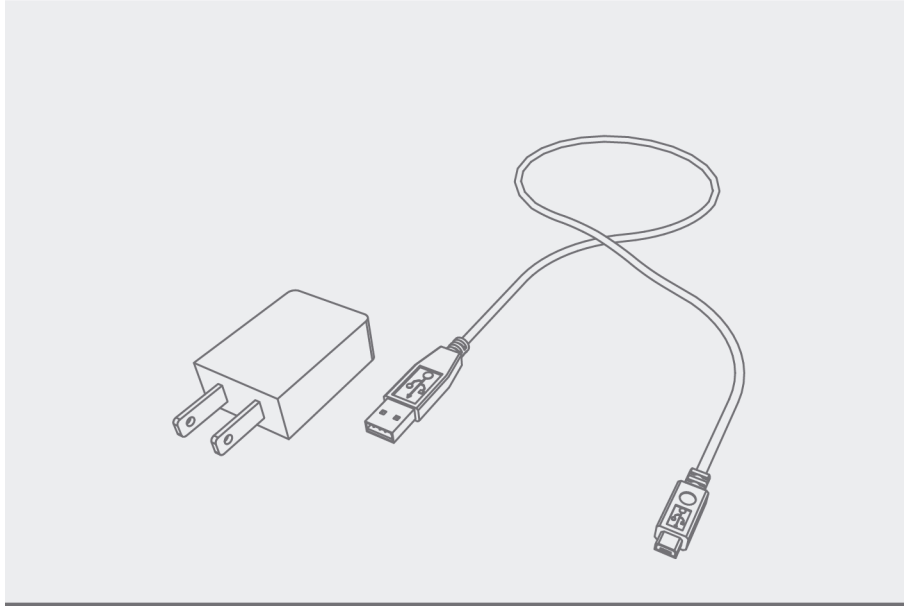

2. Connect the USB cable into the charger head. Make sure you have connected the USB cable all the way in as shown in the image below:

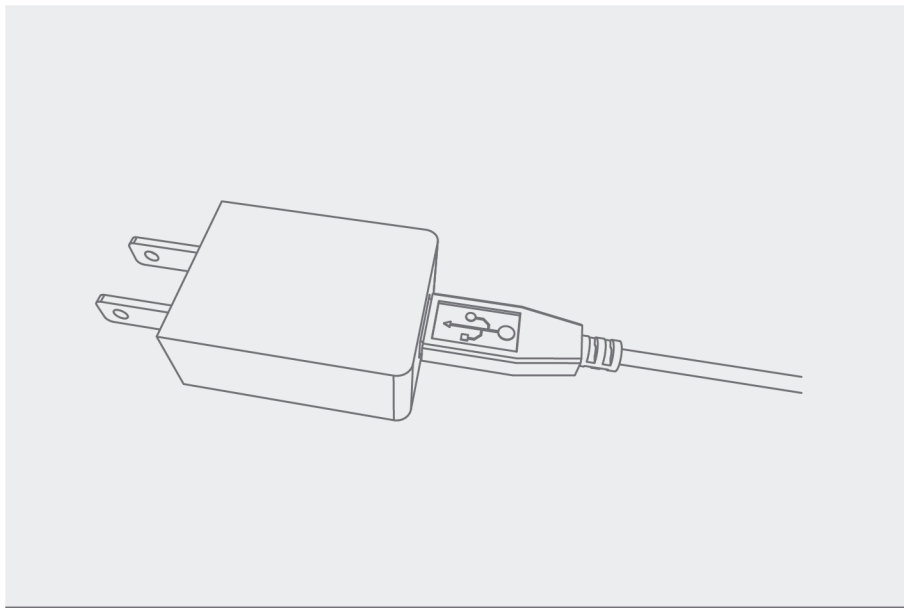

3. Connect the USB charger to an outlet nearby.
4. Plug the USB cable into the USB port. See the image below:

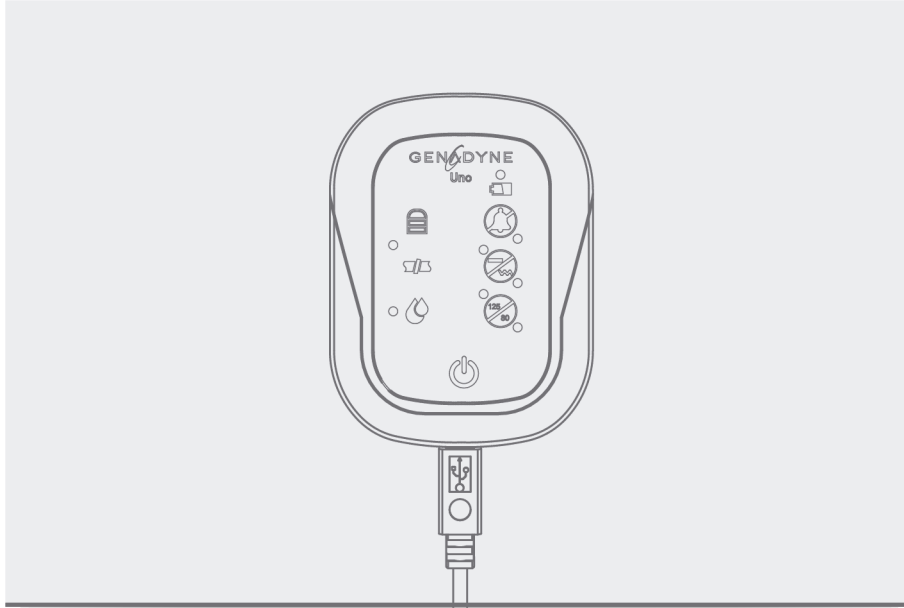

5. Let the unit charge for approximately 5 hours. The red light in the lower part of the UNO unit will indicate that the unit is charging. See the image below:

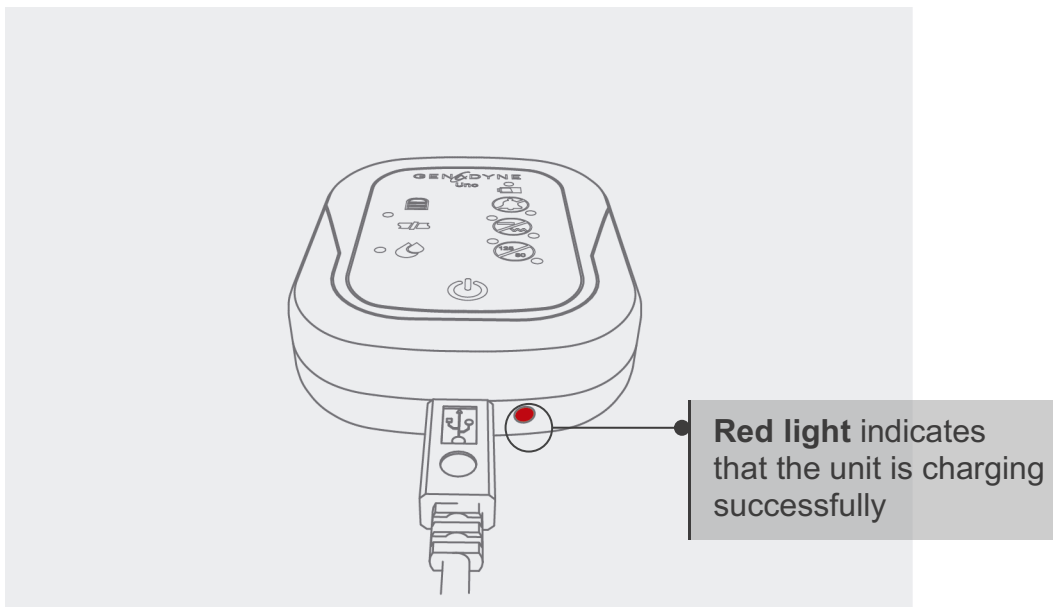

6. Once completely charged, the LED will turn green. See image below:

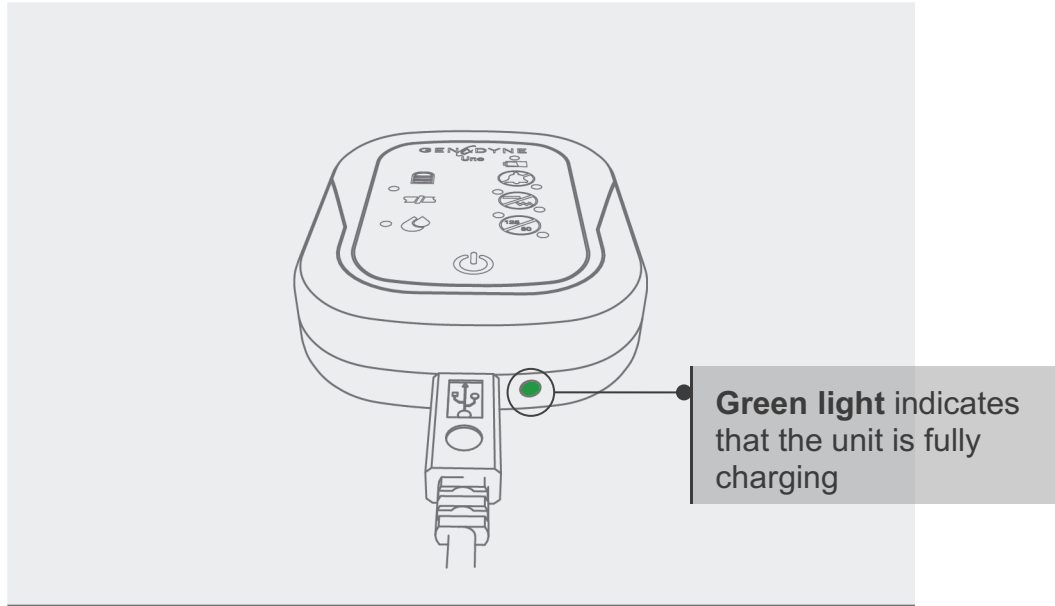

7. Unplug the charger from the outlet.

Note: The UNO can be fully operational while charging.

Warning: It is unsafe to use the device with USB charger and USB cable not provided in Genadyne UNO kit. This could potentially lead to product malfunctioning.

Symbols



Genadyne UNO NPWT System Label Reproduction



Equipment Classification
Isolation Type BF Applied Part



Single Use Only



Date of Manufacture



Place of Manufacture



Storage Temperature



Biohazard



Keep Dry



EU:
Not for General Waste



Serial Number



Caution:
Read Instructions Before Use



Lot Number



Product Reference Number



Authorized European Representative



Notified Body CE Mark

IP22

Protected against solid foreign object of 12.5 mm Ø and greater. Protected against dripping water when tilted up to 15°

Rx Only

Caution: Federal (US) Law restricts this device to sale/rental by or on the order of a physician



SGS Listed, Conforms to AAMI ES 60601-1 1st edition, CSA C22.2#60601-1 3rd edition and IEC 60601-1 3rd edition.



Caution: MR Unsafe



Do not use if package is damaged or open.

Electromagnetic Compatibility

Guidance and manufacturer's declaration – electromagnetic emissions

The Genadyne UNO is intended for use in the electromagnetic environment specified below. The customer or the user of the Genadyne UNO should assure that it is used in such an environment.

Emission Test	Compliance	Electromagnetic environment - guidance
RF emissions CISPR 11	Group 1	The Genadyne UNO does not intentionally generate any RF energy. Its parasitic emissions are kept to minimum via circuit design therefore th RF emissions are very low and are not likely to cause any interference in nearby electronic equipment.
RF emissions CISPR 11	Class B	
Harmonic emissions IEC 61000-3-2	Class A	Genadyne UNO is suitable for use in all establishments including domestic establishments and those directly connected to the public low-voltage power supply network that supplies building used for domestic purposes.
Voltage fluctuations/ flicker emissions IEC 61000-3-3	Compliant	

The Genadyne UNO is intended for use in the electromagnetic environment specified below. The customer or the user of the Genadyne UNO should assure that it is used in such an environment.

Immunity test	IEC 60601 Test level	Compliance level	Electromagnetic environment – guidance
Electrostatic discharge (ESD) IEC 61000-4-2	+/- 8 kV contact +/- 2 kV, ±4 kV, ± 8kV, ±15 kV air	+/- 8 kV contact	Floors should be wood, concrete or ceramic tile. If floors are covered with synthetic material, the relative

		+/- 2 kV ±4 kV, ± 8kV, ±15 kV air	humidity should be at least 41%.
Electrical fast transient / burst	+/- 2 kV for power supply lines	Below maximum permissible limit	mains power quality should be that of a typical commercial or hospital environment.
IEC 61000-4-4	+/- 2 kV for input / output lines	Acceptable performance	Mains power quality should be that of a typical commercial or hospital environment.
Surge	+/- 1 kV line(s) to line(s)		
IEC 61000-4-5	+/- 2 kV line(s) to earth		
Voltage dips, short interruptions and voltage variations on power supply input lines	< 5% Ut (>95 % dip in Ut) for 0.5 cycle 40% Ut (60% dip in Ut) for 5 cycles	Not Applicable	Not Applicable
IEC 61000-4-11	70% Ut (30% dip in Ut) for 25 cycles <5% Ut (>95% dip in Ut) for 5 sec		
Power frequency (50/60 Hz) magnetic field	30 A/m	Compliant	Power frequency magnetic fields should be at levels characteristics of a typical location in a typical commercial or hospital environment
IEC 61000-4-8			

Note Ut is the a.c. mains voltage prior to application of the test level

The Genadyne UNO is intended for use in the electromagnetic environment specified below. The customer or the user of the Genadyne UNO should assure that it is used in such an environment.

Immunity Test	IEC 60601 test level	Compliance level
Conducted RF IEC 61000-4-6	6 Vrms 50 MHz to 54 MHz	Not Applicable
Radiated RF IEC 61000-4-3	10.0 V/m 80 MHz to 2700 MHz	10.0 V/m



Interference may occur in the vicinity of equipment marked with the following symbol:

Note 1: At 80 MHz and 800 MHz, the higher frequency range applies.

Note 2: These guidelines may not apply in all situations. Electromagnetic propagation is affected by absorption and reflection from structures, objects and people.

The Genadyne UNO is intended for use in an electromagnetic environment in which radiated RF disturbances are controlled. The customer or the user of the Genadyne UNO can help prevent electromagnetic interference by maintaining a minimum distance between portable and mobile RF communications equipment (transmitters) and the Genadyne UNO as recommended below, according to the maximum output power of the communications equipment.

Rated maximum output power of transmitter W	Separation distance according to frequency of transmitter (m)		
	150 kHz to 80 MHz	80 MHz to 800 MHz	800 MHz to 2.5 GHz
0.01	Not Applicable	0.12 m	0.23 m
0.1	Not Applicable	0.37 m	0.74 m
1	Not Applicable	1.17 m	2.34 m
10	Not Applicable	3.70 m	7.40 m
100	Not Applicable	11.70 m	23.40 m

Specifications

Service Life/ Product Lifetime	Service life depends on the programmed time 7 days, 15 days, 30 days
Models	There are 4 models: 7 days Ref U-S00R4 15 days Ref U-S00R5 30 days Ref U-S00R6 **DEMO Ref U-S00RD (not for clinical use)
Therapy mode	Continuous / Variable
Maximum Dimensions	3" × 4 3/8" × 2 1/4" (76 × 111 × 57 mm)
Weight (including batteries & empty canister)	0.5 lb. (0.23 kg)
Battery Type	3.6V, 1700mAh, Lithium Ion Batteries
Power	Input: 100VAC-240vAC, 50-60Hz. Output: 5V DC, 2A, 10W.
Recharge Time	~ 5 Hours
Running Time	~ 19 hours of usage time per charge ² ~12 hours with pump ON all the time
Ingress Protection	IP22
Suction Capacity (Flow rate)	~0.5 L/min
Maximum Vacuum	125 mmHg
Minimum Vacuum	30 mmHg
Mode of Operation	Continuous or Variable
Patient Protection	Type BF

² Usage is based on dressing integrity. If the dressing or film is not applied properly, then the pump will require more cycles to provide the wound with required pressure. This will shorten the pump life. If the dressing has a leakage free application, then the pump will last longer.

Storage/Transport	-20°C to 60°C, 10 – 90% RH 8.6 psia – 14.3 psia atmospheric pressure
Operating Environment	5°C to 40°C, 10 – 95% RH 700 to 1060 mbar atmospheric pressure
Software	Software version <i>There is only 1 software and depends on the key press before product release, the unit will be programmed to function at the specified time.</i>
Compliance	EN 60601-1 3 rd Edition IEC EN 60601-1-2 EN 60601-1-11 EN 60601-1-6 EN/ISO 14791 EN/ISO 10993 EN/ISO 11135-1 EN/ISO 11737-1 EN 61000-3-2 EN 61000-3-3 EN 62304 EN ISO 13485 EN ISO 15223-1 EN 62366-1 EN 1041 ISO 10079-1

Contact Information



Genadyne Biotechnologies, Inc.
16 Midland Avenue
Hicksville, NY 11801 USA



Toll Free +1.800.208.2025
Tel. +1.516.487.8787
Fax +1.516.487.7878
www.genadyne.com



Obelis S.A.
EU Representative
Bd. General Wahis 53
BELGIUM
+32 (0) 2.732.59.54 (Tel)
+32 (0) 2.732.60.03 (Fax)
www.obelis.net

GENADYNE

Distributed by

